

Ampeg[®]

CLASSIC

Analog Bass Preamp

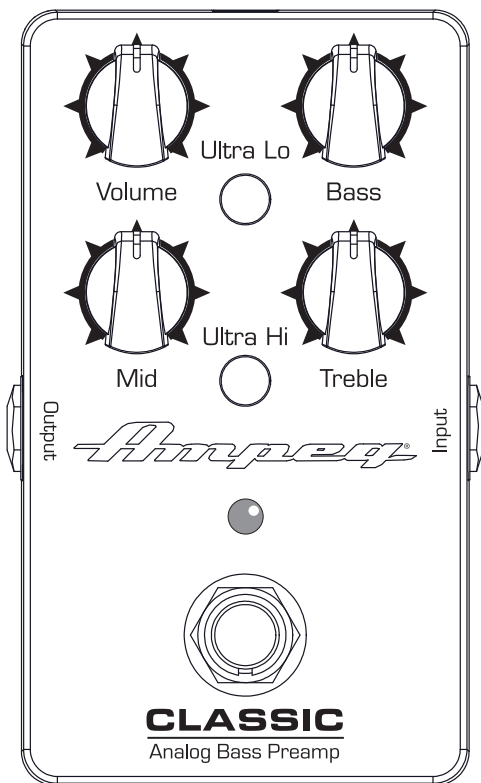

Owner's Manual



TABLE OF CONTENTS

What's in the Box	2
Introduction	2
Features	2
Top Panel Features	3
Rear and Bottom Panel Features	4
Bottom Panel Features	5
Suggested Settings	6
Block Diagram	7
Technical Specifications	8
Warranty and Support	8

What's in the Box

Classic Analog Bass Preamp Pedal, Quick Start Guide.

Introduction

The Ampeg Classic Analog Bass Preamp pedal is like having a choice of Ampeg amps right on your pedal board. Dial in a wide range of authentic Ampeg tones with the 3-band tone stack and highly flexible Ultra-Hi and Ultra-Lo circuits. It's the most affordable way into the pure analog bass tone of Ampeg.

Like all Ampeg products, your Classic Analog Bass Preamp pedal is designed by musicians and built using only the best of components. Each pedal is tested to confirm that it meets our specifications, and we believe that this pedal is the absolute best that it can be.

In order to get the most out of your new pedal, please fully read this **Owner's Manual**, as well as the **Important Safety Instructions** included with your pedal, before you begin playing. Best of luck in all of your musical endeavors!

And **thank you** for choosing Ampeg.

Features

- Delivers a wide range of authentic Ampeg tones
- Classic 3-band tone stack, plus volume
- Ultra-Hi and Ultra-Lo circuits for tonal flexibility
- True bypass, analog design with incredible signal-to-noise ratio
- Roadworthy, all-metal chassis construction
- 9V DC supply or battery capable (not included)

Top Panel Features

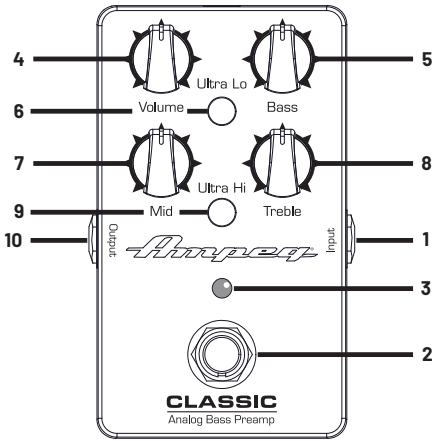

1. INPUT: The signal output from an instrument (active or passive) may be connected to this 1/4" Input by means of an unbalanced, shielded instrument cable.

NOTE: There is a -15 dB Pad Jumper located inside of the pedal. Details on switching the jumper may be found on [page 5](#).

NOTE: Unplug the input cable when not in use, as the 9V battery will drain (and eventually die). Details on replacing the battery may be found on [page 5](#).

2. CLASSIC PREAMP SWITCH: Engage this switch to activate the Classic Preamp pedal. This pedal is true bypass, meaning the signal will pass through from input to output, with no circuitry in between, when the switch is disengaged.

3.ON/OFF LED: This LED illuminates purple when the pedal is engaged.

4. VOLUME: Use this to control the overall output level. Use it wisely and turn it down when making connections or trying something new. Unity is at 12:00.

NOTE: The Volume control is active only when the pedal is engaged.

5.BASS: Use this to adjust the low frequency level. This provides up to 7 dB of boost, or 20 dB of cut, at 40 Hz. The low frequency output is flat at the center position.

6.ULTRA LO: This switch, when engaged, enhances the amount of low-end output with a 2 dB boost at 40 Hz, and -10 dB cut at 500 Hz.

7. MID: Use this to adjust the midrange frequency level. This provides up to 5 dB of boost, or 11 dB of cut, at 500 Hz. The midrange frequency output is flat at the center position.

Rotate the control counter-clockwise for a "contoured" sound, (more distant, less midrange output) or clockwise for a sound that really cuts through.

8.TREBLE: Use this to adjust the high frequency level. This provides up to 10 dB of boost, or 10 dB of cut, at 4 kHz. The high frequency output is flat at the center position.

9.ULTRA HI: This switch, when engaged, enhances the amount of high-end output by 7 dB at 8 kHz.

10. OUTPUT: Typically, this 1/4" Output jack connects to the input of an external power amplifier – or powered loudspeakers, as long as they have their own input controls to adjust the volume level – by means of an unbalanced, shielded, instrument cable.

However, it may alternatively be connected to an external mixer, recorder, or interface. In this way, you do not have to mic the speaker cabinet in order to add it to the main mix or to record. The level of the signal is affected by the Volume control when pedal is engaged.

Rear and Bottom Panel Features

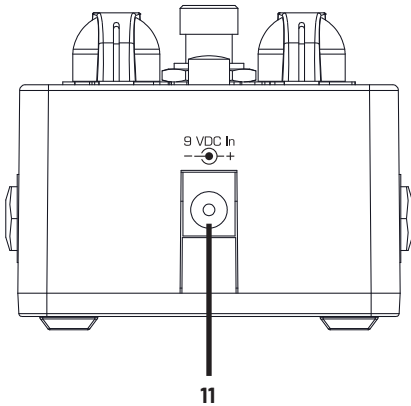

11. **POWER CONNECTOR:** This is where to connect the optional power supply.

 **NOTE:** Before plugging in the power supply, make sure that you are using the correct model power supply for this product. Failure to do so may result in damage to your unit and void your warranty.

A **DC-1G Power Supply** may be purchased from an Ampeg Dealer, or you may purchase one directly from the Ampeg Online Shop, at shop.ampeg.com.

For residents outside of the US, please request the model **DC-1G Power Supply** when purchasing from an Ampeg dealer or distributor in your region.

BOTTOM PANEL ACCESS

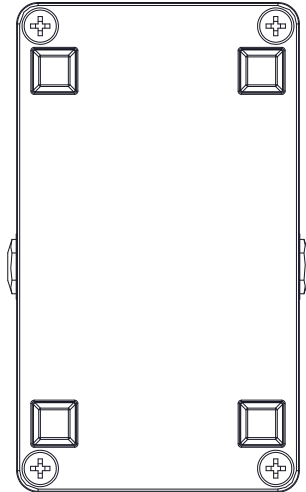

Removing the bottom is easy. Simply start by placing the pedal top down on a soft, dry cloth.

Remove each of the four screws by turning them counter-clockwise. Be sure to keep them in a safe place as you will need them again!

Bottom Panel Features

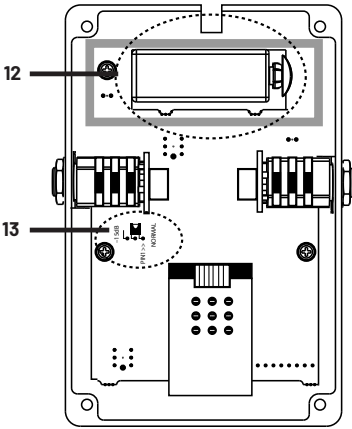

- 12. 9V BATTERY:** The Classic Analog Bass Preamp may be powered by 9V battery instead of using a power supply. As seen in the illustration above, a battery fits nicely inside a compartment of the circuit board, next to the edge of the pedal.

NOTE: Unplug the input cable when not in use, as the 9V battery will drain (and eventually die).

- 13. -15 dB PAD JUMPER:** Moving the -15 dB Pad Jumper reduces the input signal by 15 dB. This attenuation is suited for use with basses that have active electronics or high-output pickups.

There are only two possibilities. The jumper can be on:

- Pins 1-2 (Normal - default)
- Pins 2-3 (-15 dB Pad)

Ok, ok...there could be no jumper, but that just sets the pedal to its Normal/default, Pins 1-2 setting (with about 1/2 dB loss).

Referencing the above diagram, slide the jumper out then back in on the pins that you want to use for your instrument. Fingers should work just fine, but it's ok to use needle-nose pliers to remove the jumper, if necessary.

NOTE: If you are experiencing excessive distortion (distortion begins at approximately 0.5V RMS) then you might want to utilize the -15 dB Pad by moving the jumper to Pins 2-3.

NOTE: When reattaching the bottom plate to the pedal, line up the rectangular foam piece over the battery. Turn the screws clockwise to affix to the bottom to the pedal.

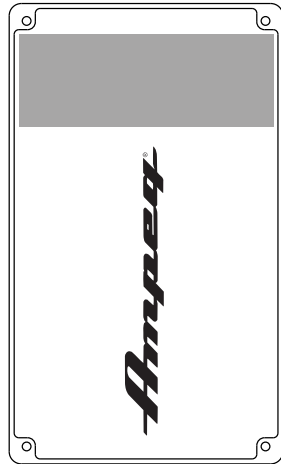

Suggested Settings

Set Volume control to taste

● = Switch engaged (down)

○ = Switch disengaged (up)

Slappin' Da Bass

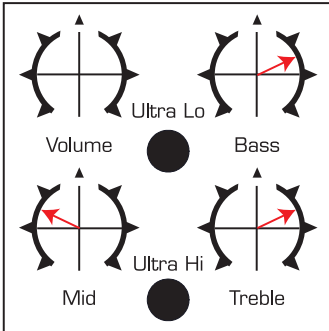

Rock

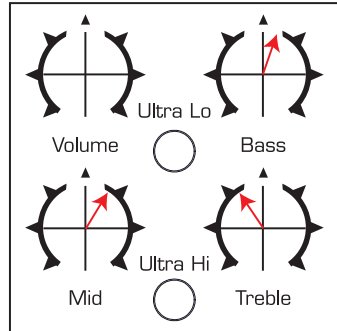

Reggae

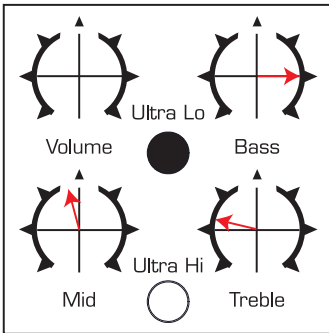

Motown

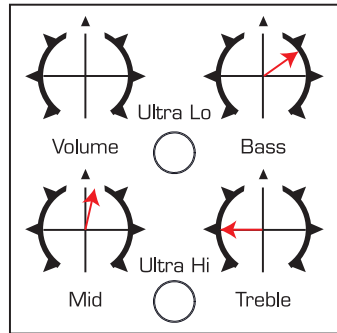

Classic Dino

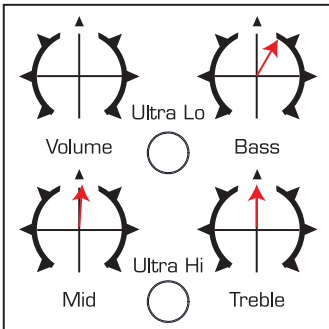

Pick/Grind

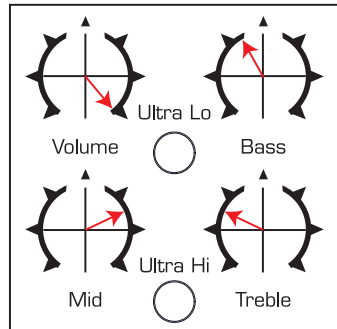

Block Diagram

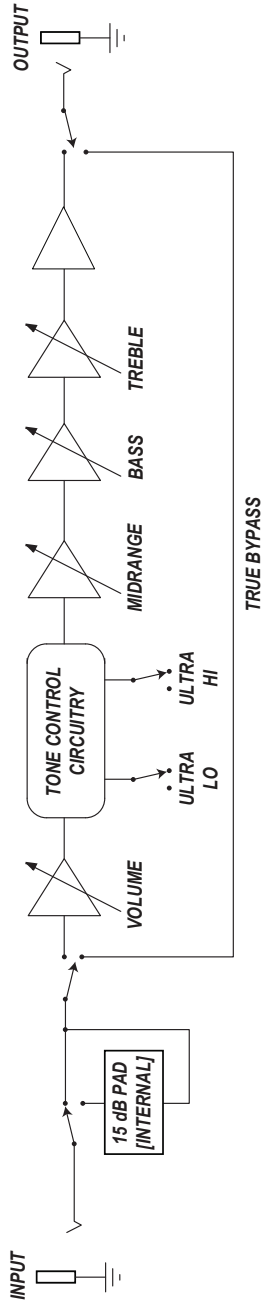

Technical Specifications

Signal to Noise Ratio (50 Hz @ 300mV RMS)	75 dB
Maximum Gain	+18 dB
Tone Controls	Bass: +7/-20 dB @ 40 Hz Mid: +5/-11 dB @ 500 Hz Treble: +10/-10 dB @ 4 kHz Ultra Hi: +7 dB @ 8 kHz Ultra Lo: +2 dB @ 40 Hz / -10 dB @ 500 Hz
Impedances	Input: 1 M Ω @ Normal, 83 k Ω w/-15 dB Pad Output: 120 Ω
Power Requirements	Internal: 9V Battery External: 9VDC, \geq 20 mA, center negative
Size (H x W x D)	2.2 in x 2.6 in x 4.5 in 56 mm x 66 mm x 114 mm
Weight	0.6 lb / 0.3 kg (approximately)

The Classic Analog Bass Preamp is housed in a corrosion resistant, die-cast zinc chassis, so be sure to clean it with a dry, lint-free cloth. Never spray cleaning agents on the Classic Analog Bass Preamp. Avoid abrasive cleansers which would damage the finish.

Ampeg continually develops new products and improves upon existing ones. For this reason, the specifications and information in this manual are subject to change without notice.

Warranty and Support

Visit WWW.AMPEG.COM to...

- (1) ...identify **WARRANTY** coverage provided in your local market. Please keep your sales receipt in a safe place.
- (2) ...**REGISTER** your product.
- (3) ...**CONTACT** Technical Support, or call 818-575-3600.

www.ameg.com
Yamaha Guitar Group, Inc.
26580 Agoura Road, Calabasas, CA 91302-1921 USA
Rev. A

